

# CODESYS

## Features and Improvements

### CODESYS V3.5 SP15

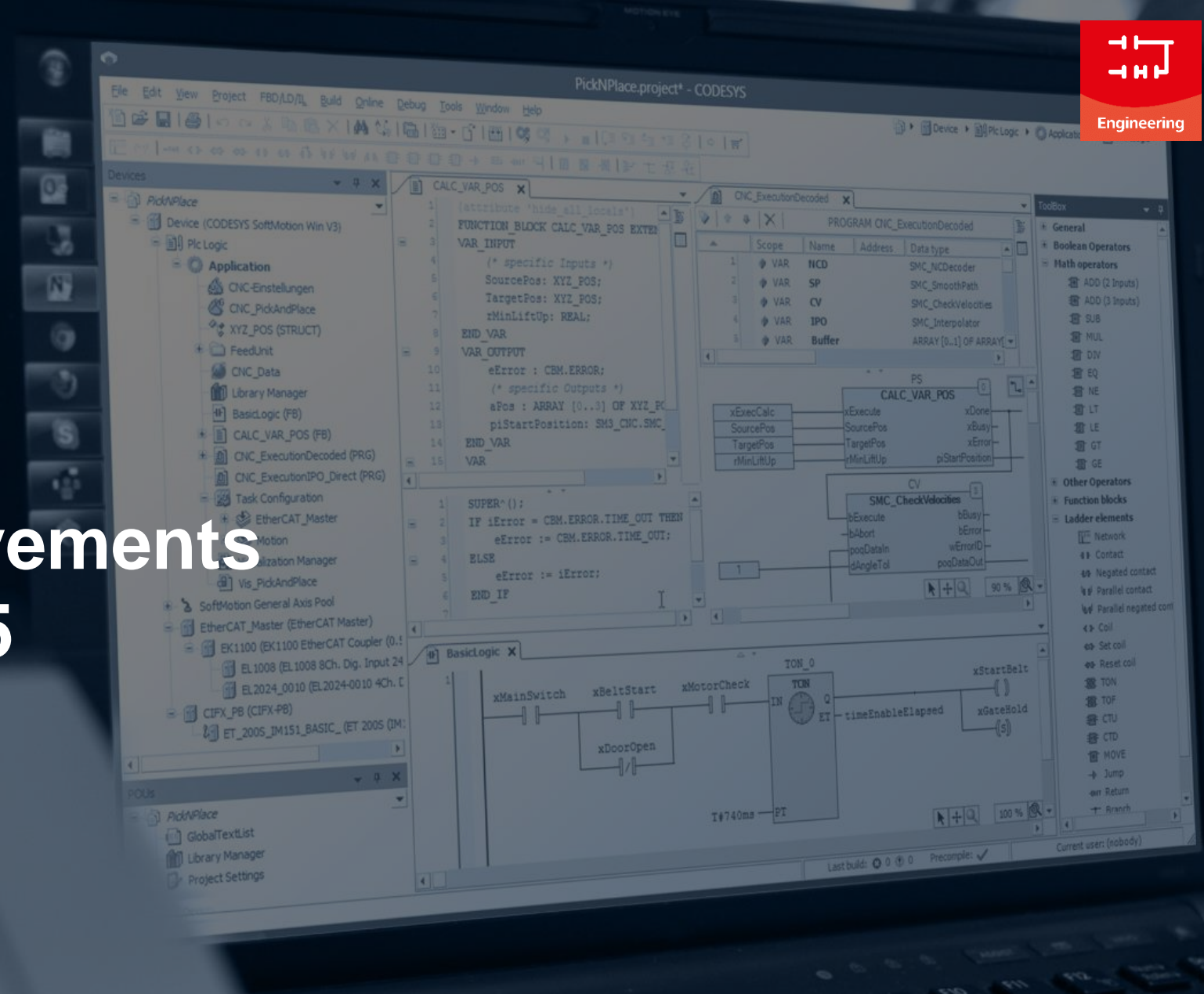

**1**

**Engineering**

**2**

**Runtime**

**3**

**Visualization**

**4**

**Motion CNC Robotics**

**5**

**Fieldbus**

**6**

**Safety**

## Overview

- **CFC: Update of the editor**
- **Signing of Libraries**
- **Converter for CODESYS V2.3 objects**
- **CODESYS Device Reader**
- **Chromium web browser**
- **CODESYS Profiler**
- **CODESYS Test Manager**
- **Further improvements**

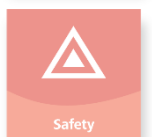
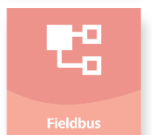
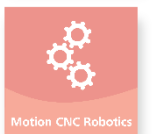
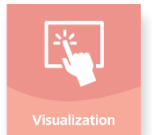

## CFC: Update of the Editor

- **Auto Dataflow Mode as new default setting:**
  - Execution order automatically according to data flow – top to bottom, left to right
  - Starting at the start point of each data flow

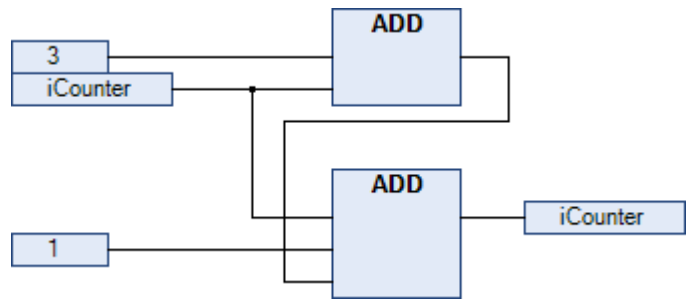

- **Execution order display: now temporary as overlay**

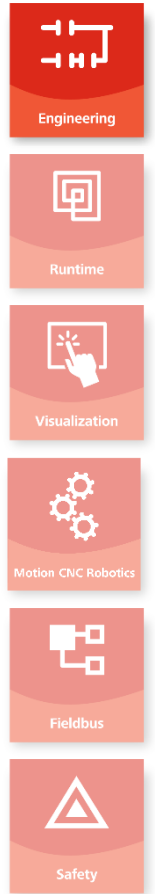
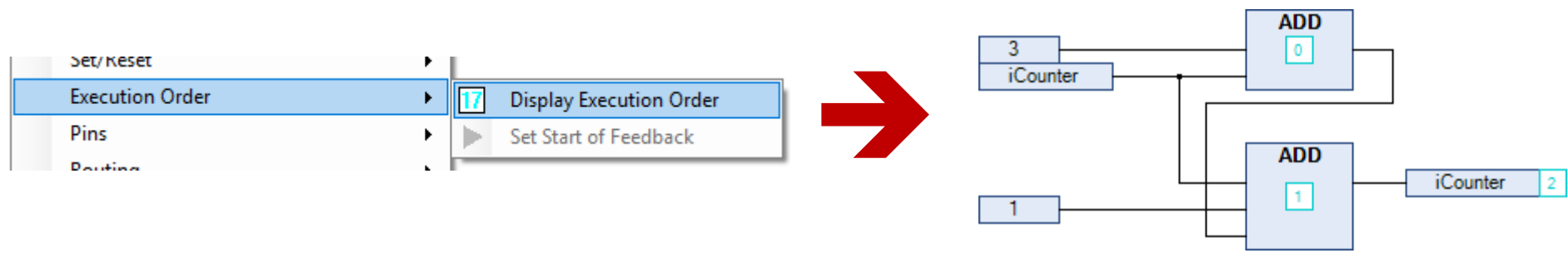

## CFC: Update of the Editor

- CFC execution order adaptable in POU properties

Properties - POU [Device: PLC Logic: Application]

Common Build **CFC Execution Order** Access Control Bitmap

Execution order **Auto Data Flow Mode** [help](#)

The execution order will be automatically sorted by data flow. You do not have to take care about the execution order any more. The execution order marks will not be shown any more. But after toggling the new 'Display Execution Order' command, they are visible until the next modification. This setting is recommended. But keep in mind: Using this option may reorder your code which may lead to a different behavior or online change.

Properties - POU [Device: PLC Logic: Application]

Common Build **CFC Execution Order** Access Control Bitmap

Execution order **Explicit Execution Order Mode** [help](#)

This is the up to now usual behavior. The execution will be shown at the right upper corner and you have to take care about it on your own. You can use several commands to modify the execution order (for example 'Order by Data Flow').

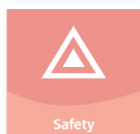
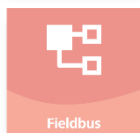
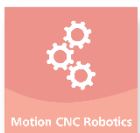
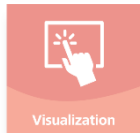

## CFC: Update of the Editor

- Explicit start point for feedback loops

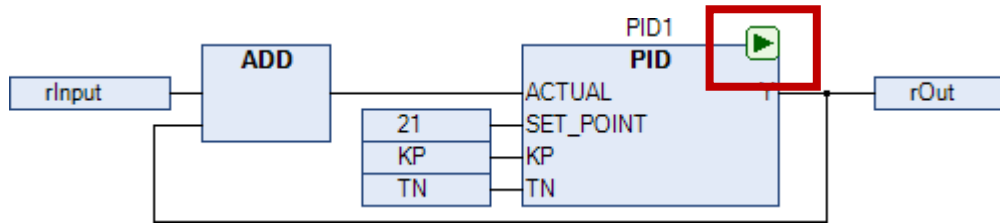

- Drag and drop of variables

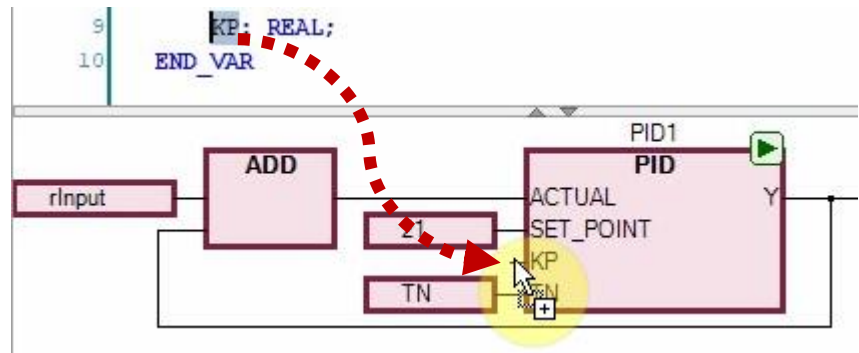

- Autorouting errors for connection lines fixed

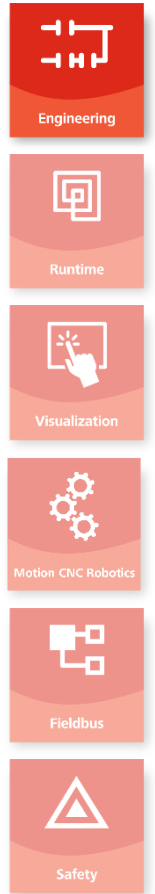

## Signing of Libraries

- Signing of compiled libraries supported
- Activation via the Security Screen

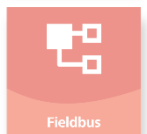
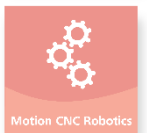
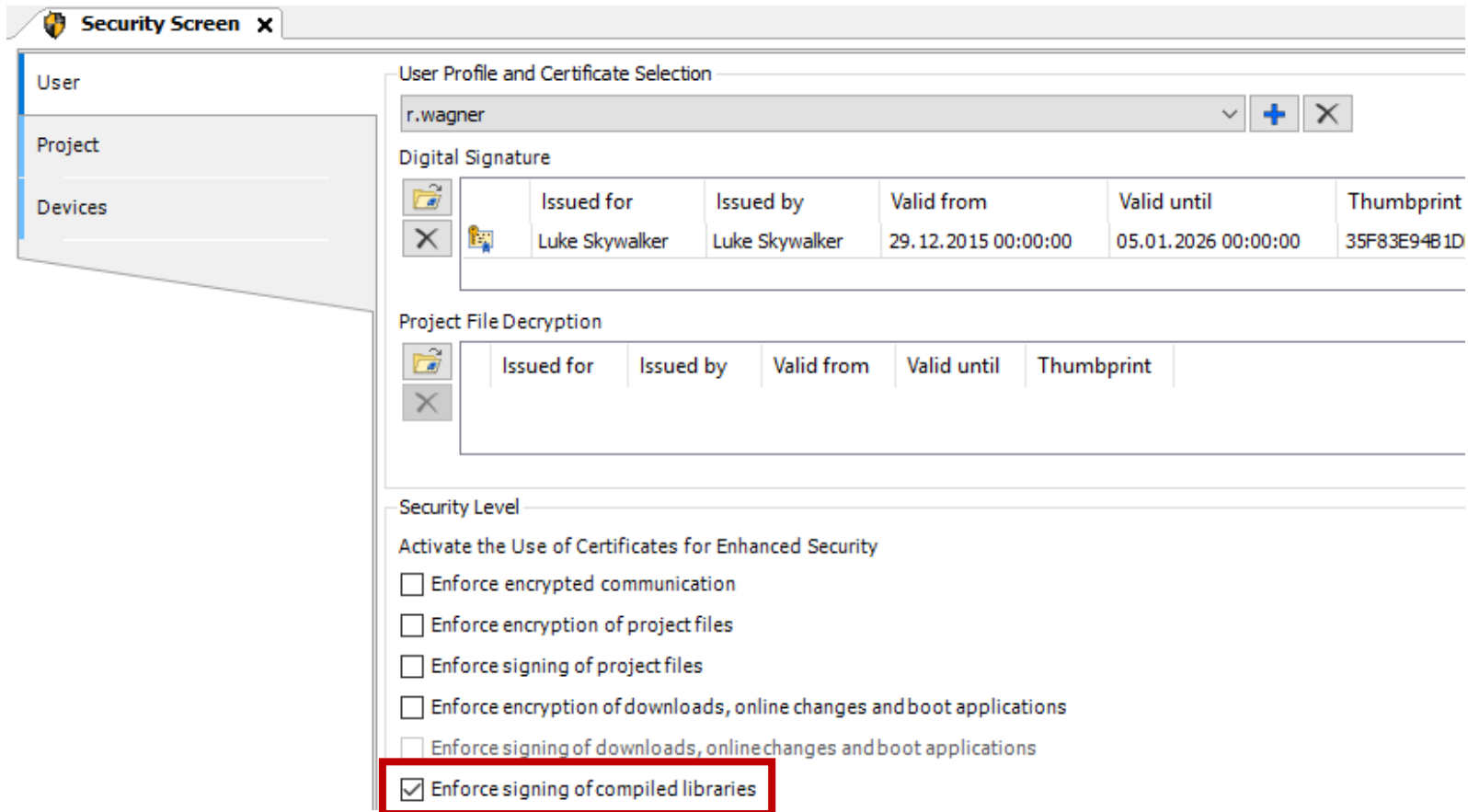

## Signing of Libraries

- New labeling of icons in the Library Manager

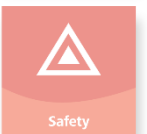
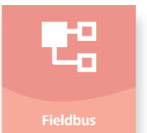
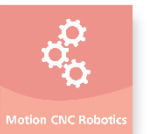
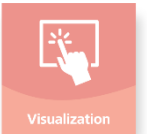
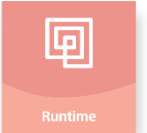
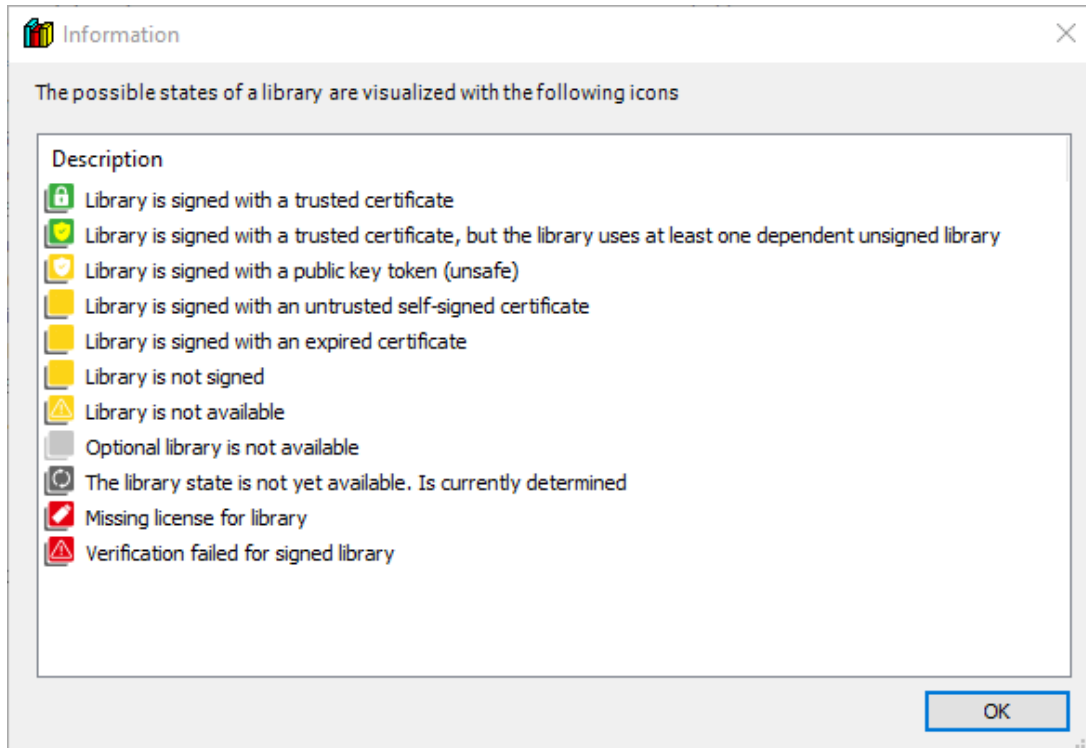
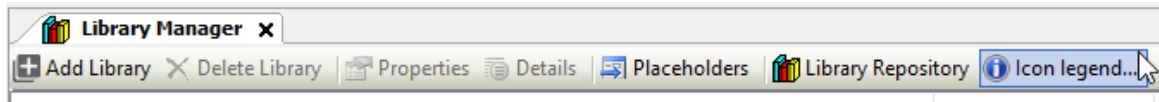



## Converter for CODESYS V2.3 objects

- Converter moved from the standard installation to a separate package
- Package available at the CODESYS Store free of charge:  
<https://store.codesys.com/codesys-v23-converter.html>



### CODESYS V2.3 Converter

The CODESYS V2.3 Converter enables you to open and import projects edited with CODESYS V2.3 with CODESYS V3.5.

Version: 3.5.15.0  
Order number: 000109

☆☆☆☆☆  
No rating available  
Add Your Review

€0.00  
plus VAT

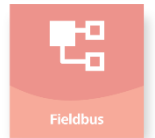
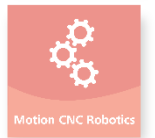
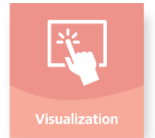

## CODESYS Device Reader

- New as of SP15: CODESYS Device Reader as plug-in for the CODESYS Development System

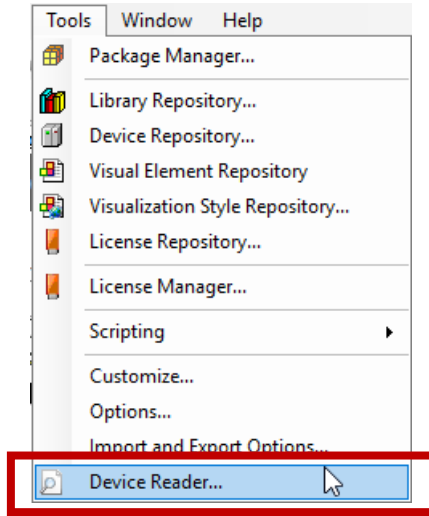

A screenshot of the 'Device Reader' window. The window title is 'Device Reader'. It displays a table titled 'Status of available device features' with three columns: 'Product', 'Feature', and 'License Active/Count'. The table lists various products and their features, along with their license status.

Product	Feature	License Active/Count
TargetVisu		Yes
WebVisu		Yes
RemoteVisuClient		Yes
SoftMotion	Basic	Yes
SoftMotion	CNC	Yes
SoftMotion	Trafo	Yes
SoftMotion	Light	No
SoftMotion	CNC restricted	No
FDT		Yes
CANopen	Slave	Yes
CANopen	Master	Yes
CANopen	Safety Slave	No
CANopen	Safety Master	No
EtherCAT		Yes
EtherCAT	EL6731 Master	Yes
EtherCAT	EL6631 Master	Yes
EtherCAT	EL6731-0010 Slave	Yes

- Still available: CODESYS Device Reader at the CODESYS Store free of charge  
<https://store.codesys.com/device-reader.html>

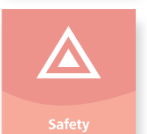
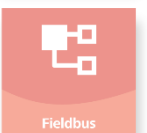
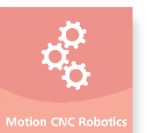
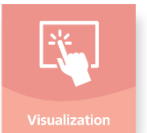
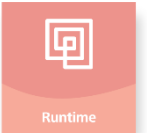
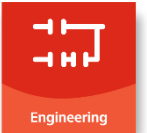

## Chromium web browser

- **Chromium Embedded Framework implemented and used by**
  - Library documentation in the Library Manager
  - Overlay in the WebVisu when in online mode

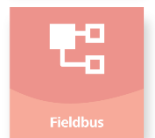
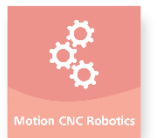
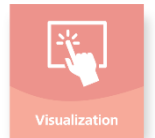

# CODESYS Profiler

- **New user interface and handling concept**
  - Moved from toolbar to application context menu
  - Each application has its own Profiler object
  - Profiler settings adjustable per application
- **Specifiable selection of POU's and source libraries**

POU selection

Name	
Application	<input checked="" type="checkbox"/>
PLC_PRG	<input type="checkbox"/>
POU_CFC	<input checked="" type="checkbox"/>
POU_ST	<input type="checkbox"/>
POU_ST.ACT	<input checked="" type="checkbox"/>
POU_ST.METH	<input type="checkbox"/>

- **Profiler results can be saved permanently (Snapshots)**

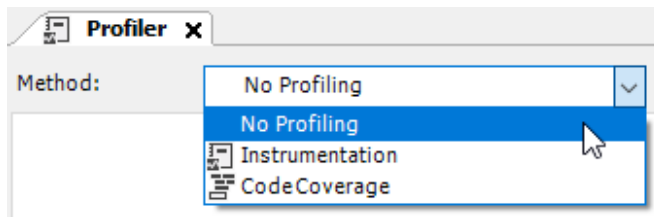
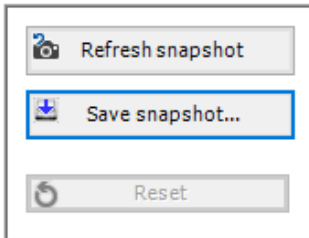

- **Profiling methods selectable**

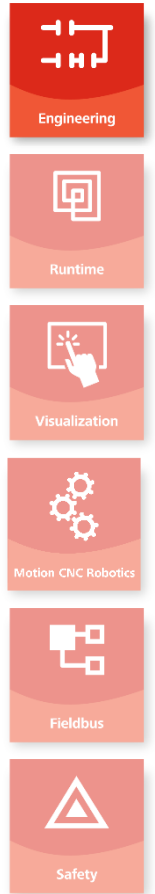
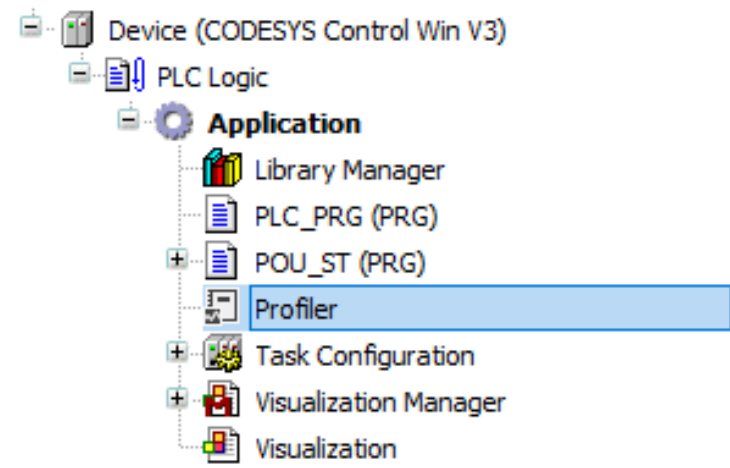
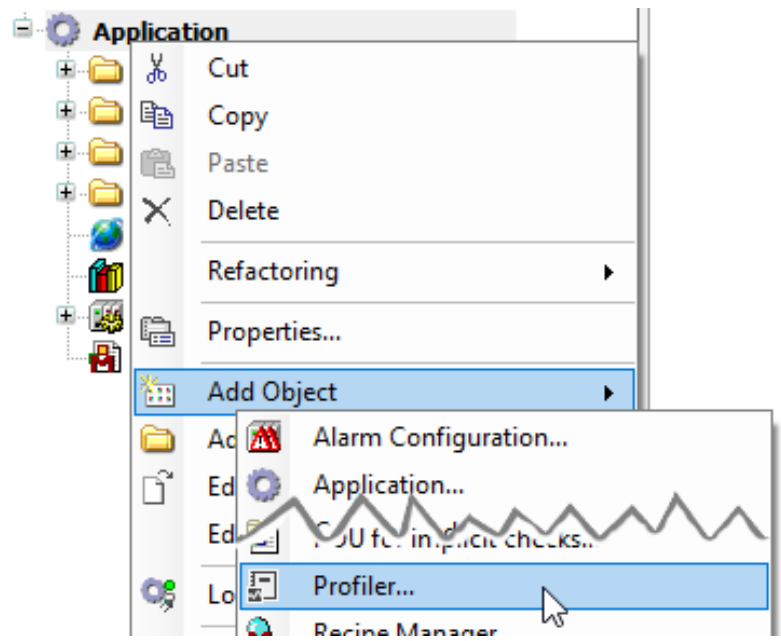

## CODESYS Test Manager

- **New debugging features for the test script procedure**
  - Halt, step, continue of the test script
  - Display of test script variables during runtime
  - Breakpoints, halt on error
  - Test script elements can be commented out
- **Pins for test scripts**
  - Checksum of scripts (XML signature)
  - Reporting of the test script status (version + pin)

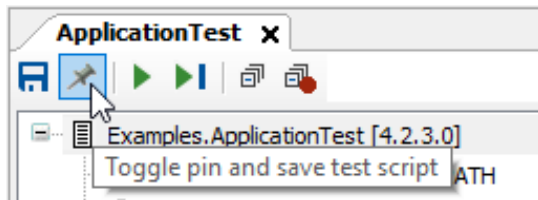

- **IEC unit test**

- Test case selection via blacklist and whitelist
- Declaration of test cases as script variable

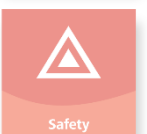
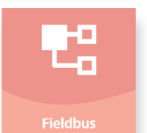
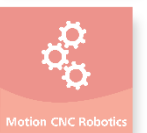
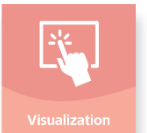
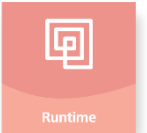
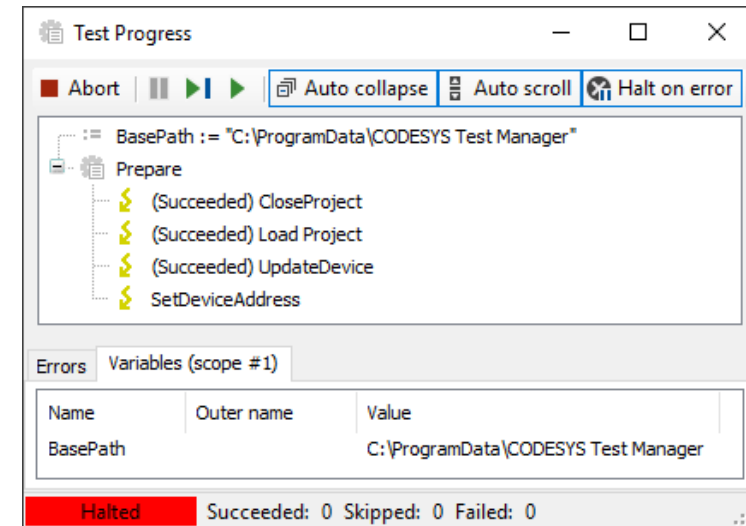
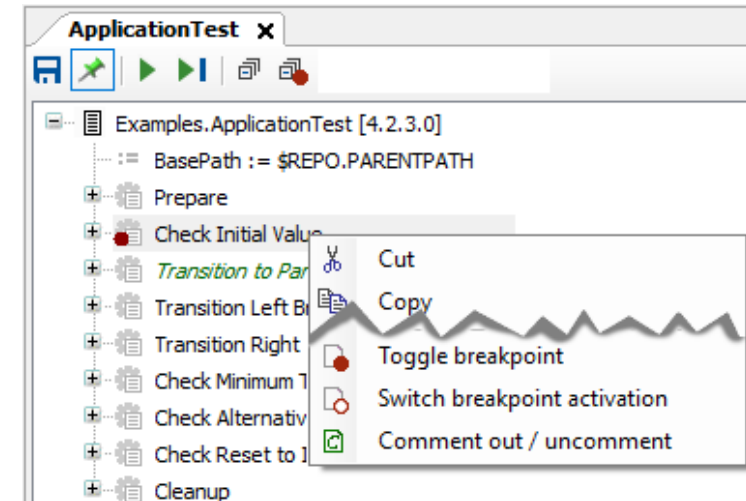

## Further improvements

- Drop down box for selection of active application

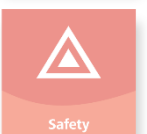
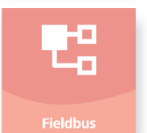
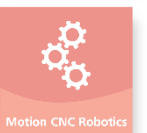
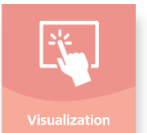
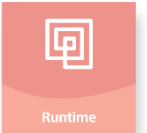
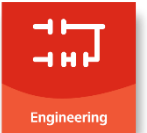
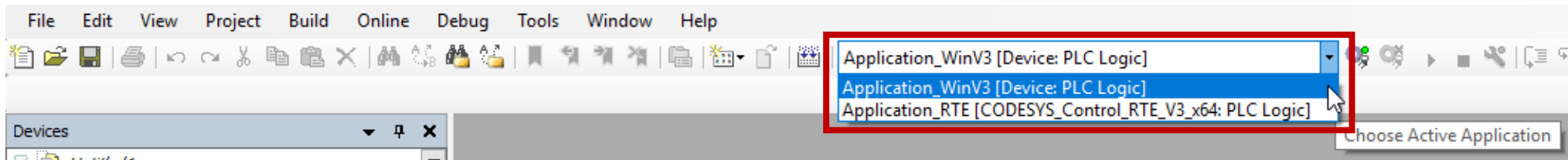

1

**Engineering**

2

**Runtime**

3

**Visualization**

4

**Motion CNC Robotics**

5

**Fieldbus**

6

**Safety**

## Overview

- **CODESYS Edge Gateway**
- **New / updated SoftPLCs in the CODESYS Store**
- **In preparation: CODESYS OPC UA Client**
- **Further Improvements**

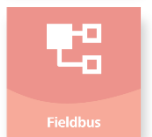
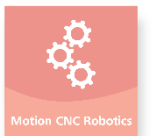
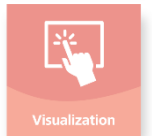
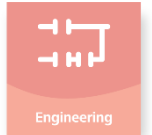



## CODESYS Edge Gateway

- **Central juncture between CODESYS Automation Server and controller landscape**
- **Available free of charge at the CODESYS Store**
  
- **Available as (scheduled for CODESYS 3.5 SP15 Patch 1)**
  - Runtime component
  - Stand-alone installation for Windows and Linux
- **Configurable with the CODESYS Automation Server Connector (CODESYS Store)**

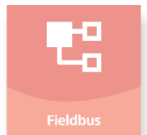
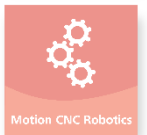
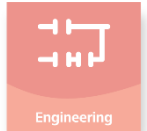

## New SoftPLC in the CODESYS Store

### ■ CODESYS Control for PLCNext SL

- Adapted CODESYS Control runtime system for Phoenix PLCnext AXC F2152 controller
- Multicore extension available
- Features
  - CODESYS EtherCAT Master
  - CODESYS Modbus TCP Master / Slave
  - CODESYS PROFINET Controller / Device
  - CODESYS Ethernet IP Scanner / Device
  - CODESYS WebVisu
  - CODESYS OPC UA Server
  - Local IOs (AXIO extension modules)

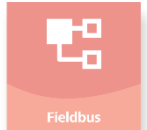
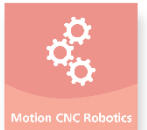
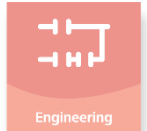

## Updated SoftPLCs in the CODESYS Store

- **CODESYS Control for Linux SL:**  
Software-based licensing via CODESYS Soft Container
- **CODESYS Control for emPC SL:**  
Multicore-Support
- **CODESYS Control for Raspberry Pi SL:**  
Removal of CODESYS SoftMotion license – available as separate product now

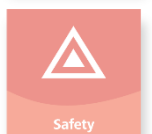
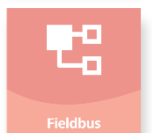
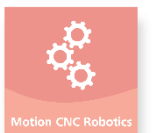
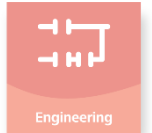

## OPC UA Client

- **CODESYS OPC UA Client prototype ready**
- **Release scheduled for CODESYS 3.5 SP16**

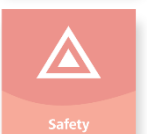
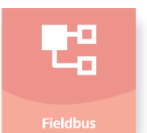
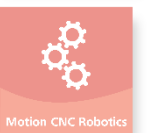
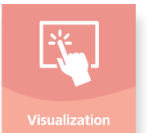
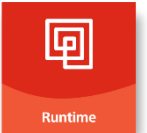
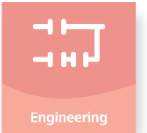

## Further Improvements

- **VxWorks**
  - Improved timing behavior for smaller jitter, e.g. for EtherCat Distributed Clocks, motion applications
- **CmpLog**
  - Logger time stamp for console windows and log files in ISO8601 format
- **lecVarAccess**
  - Significant read/write access improvements (~ access time halved)
- **CmpOpenSSL updated to OpenSSL version 1.1.1 (realized according to C99)**

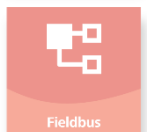
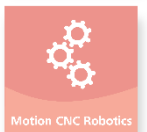
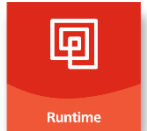
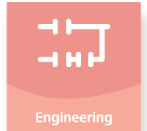

1

**Engineering**

2

**Runtime**

3

**Visualization**

4

**Motion CNC Robotics**

5

**Fieldbus**

6

**Safety**

## Overview

- **New alarm table feature**
- **Combo box**
- **Trace and trend**
- **Chromium web browser**

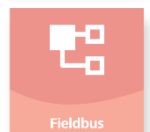
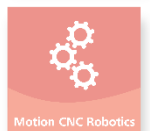
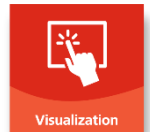
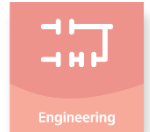

## New alarm table feature: Filter by latch variable

- Filtering by arbitrary values of the latch1 variable
- Optimized implementation for high-performance filtering of a large number of alarms
- Filtering on controller / database side for avoiding unnecessary data transfer (in case of HMI)
- Four filter options: unfiltered, by string comparison, by IEC literal, by integer

Properties

Filter | Sort by | Sort order | Advanced

Property	Value
Element name	GenElemInst_1
Type of element	Alarm table
Data source	<local application>
Alarm configuration	
Alarm groups	All
Priority from	0
Priority to	255
Alarm classes	All
Filter by latch 1	
Filter variable	
Filter type	
General table configuration	
Columns	Create new
Position	
Text properties	

AlarmGroup

Textlist: AlarmGroup | Archiving: (none) | Deactivation:

ID	Observation Type	Details	Deactivation	Class	Message	Min. Pend. Time	Latch Var 1	Latch Var 2	Higher Prio. Alarm
11	Digital	PLC_PRG.xAlarm11 = TRUE		Warning	Alarm 11 aktiv, this is a v...		PLC_PRG.xTrigger		
12	Digital	PLC_PRG.xAlarm12 = TRUE		WarningOrange	Hallo world Test				
13	Digital	PLC_PRG.xAlarm13 = TRUE		Warning	Alarm 13 active				

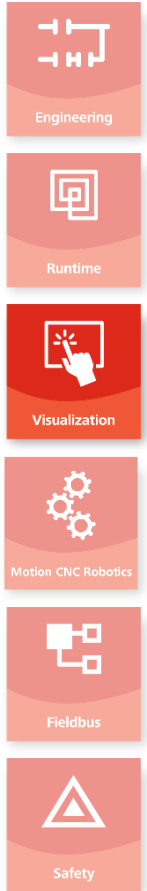



## Combo box

- Combo box supports dynamically selected text list
- Easy handover of text list by a string variable

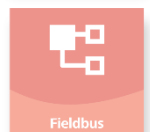
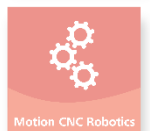
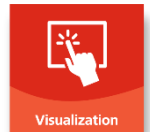
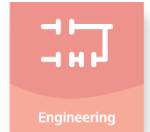

## Trace and trend

- Additional color configuration for traces and trends, e.g. support for dark backgrounds

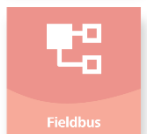
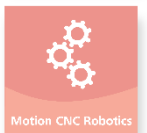
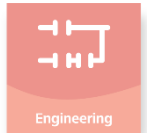
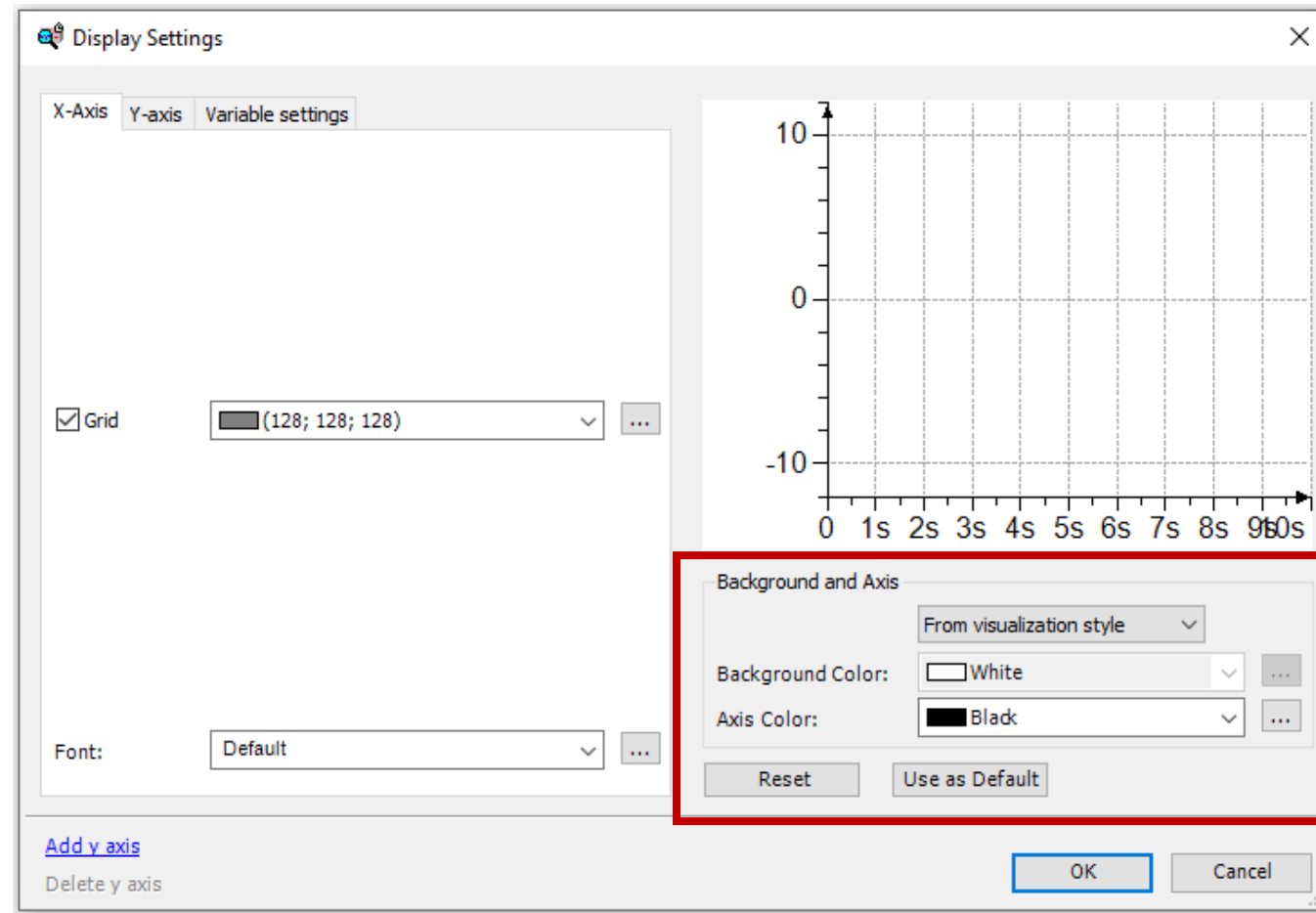

## Chromium web browser

- Online mode realized by means of Chromium Embedded Framework
- All online functions of the WebVisu can now be displayed in the CODESYS Development System, no separate browser necessary

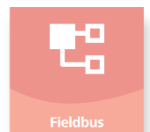
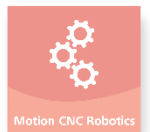
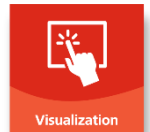
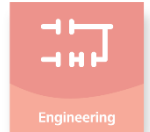

1

**Engineering**

2

**Runtime**

3

**Visualization**

4

**Motion CNC Robotics**

5

**Fieldbus**

6

**Safety**

## Overview

- Drive support
- Robotics improvements
- Further improvements

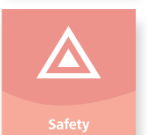
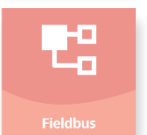
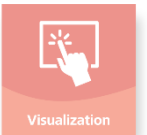
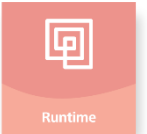
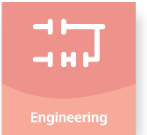

## Drive support

- **New drivers for**
  - Hitachi ADV
  - Yaskawa Sigma 7
  - CMZ LBD
  - Delta ASDA A2
- **Updated drivers for**
  - Panasonic MINAS A5B und A6B  
Communication with Panasonic configurator “Panaterm“ for drives, integrated in CODESYS
  - Parker PSD  
New drive functions, test with safety modules

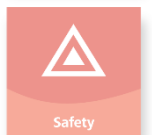
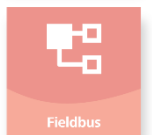
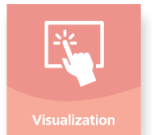
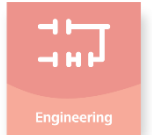

## Robotics improvements

- **Path fidelity during jogging**
  - During cartesian jogging, robot remains on straight path regardless of axis limits
- **Improved blending for pick and place**
  - Improved blending for very fast pick and place applications
- **Workspace of 6-axis robot**
  - Extended possible range of 1<sup>st</sup> and 4<sup>th</sup> axis to more than 360°
- **Extension of SMC\_SetControllerMode**
  - Extension of SMC\_SetControllerMode by new mode „no\_control“
  - Allows for controlling the axis either by application or by CODESYS SoftMotion
- **MC\_Stop/MC\_Halt**
  - Allows to avoid a reversal of the drive during MC\_Stop/MC\_Halt in any case by activating a specific option

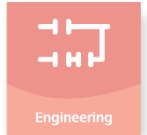

Engineering



Runtime



Visualization



Motion CNC Robotics

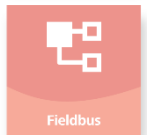

Fieldbus



Safety

## Further improvements

- **Multicore capability**
  - Comprehensive multicore capability of CODESYS Motion CNC Robotics
  - CPU-intensive processes can be assigned to dedicated cores, e.g. robotic planning task, path preprocessing, G-code decoding
  - Significant reduction in peak load due to distribution across multiple cores
- **Programmed path can be continued after an error, e.g. after a position deviation error**
  - Previously all programmed movements were discarded and had to be reprogrammed after acknowledgement.

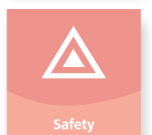
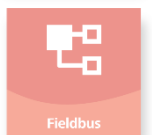
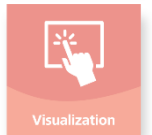
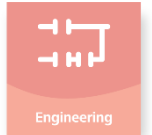



1

**Engineering**

2

**Runtime**

3

**Visualization**

4

**Motion CNC Robotics**

5

**Fieldbus**

6

**Safety**

## Overview

- **Extensive improvements of diagnostic capabilities**
- **Updates of**
  - CODESYS EtherCAT
  - CODESYS PROFINET
  - CODESYS ETHERNET/IP Scanner/Adapter
  - CODESYS CAN
  - CODESYS Modbus
  - Further improvements

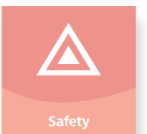
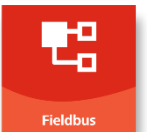
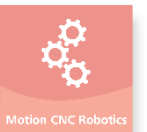
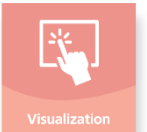
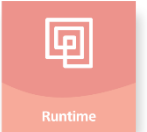
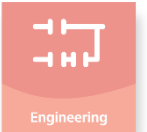

## Extensive improvements of diagnostic capabilities

- PLC Log: User defined sorting of table columns

0 warning(s) 0 error(s) 0 exception(s) 181 information(s) 0 debug message(s) <All components>

Offline logging  UTC time

Severity	Time Stamp	Description
i	15.07.2019 10:48:10.733	CODESYS Control Win V3
i	15.07.2019 10:48:10.733	OS=Windows, CPU=x86, Arch=32Bit, Coding=C
i	15.07.2019 10:48:10.733	3.5.15.0 Jul 12 2019
i	15.07.2019 10:48:10.733	Copyright (c) 3S - Smart Software Solutions GmbH
i	15.07.2019 10:48:10.733	System: CM, 0x00000001 3.5.15.0
i	15.07.2019 10:48:10.733	System: CmpMemPool, 0x0000001e 3.5.15.0
i	15.07.2019 10:48:10.733	System: CmpLog, 0x00000013 3.5.15.0
i	15.07.2019 10:48:10.733	System: CmpSettings, 0x0000001a 3.5.15.0
i	15.07.2019 10:48:10.733	System: SysFile, 0x00000104 3.5.15.0

- Expandable logger messages

i	15.07.2019 10:48:14.295	NetID 0, NodeID 2: SDO configuration phase finished
i	15.07.2019 10:48:14.295	NetID 0, NodeID 1: Slave signals CANopen state: OPERATIONAL
i	15.07.2019 10:48:14.275	NetID 0, NodeID 1: NMT START
i	15.07.2019 10:48:14.255	NetID 0, NodeID 1: SDO configuration phase finished
i	15.07.2019 10:48:13.955	NetID 0, NodeID 2: Begin SDO configuration phase...
		Number of SDOs: 16
i	15.07.2019 10:48:13.950	Setting router 3 address to (1be9:0001)
i	15.07.2019 10:48:13.935	NetID 0, NodeID 2: Reading Identity Object 16#1018...
+	15.07.2019 10:48:13.915	NetID 0, NodeID 1: Begin SDO configuration phase...
i	15.07.2019 10:48:13.895	NetID 0, NodeID 1: Reading Identity Object 16#1018...

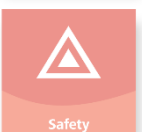
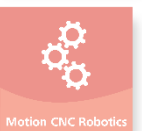
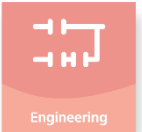

## Extensive improvements of diagnostic capabilities

- Separate logger page for each device with specifically filtered error messages

The screenshot displays the CODESYS software interface. On the left, a tree view shows the project structure under 'DiagnosisMaster', including 'Device [connected] (CODESYS Control Win V3)', 'PLC Logic', 'Application [run]', 'Library Manager', 'PLC\_PRG (PRG)', 'Task Configuration', 'MainTask (IEC-Tasks)', 'PLC\_PRG', 'CANbus (CANbus)', 'CANopen\_Manager (CANopen\_Manager)', 'CANopenDevice (CANopenDevice)', and 'CANopenDevice\_1 (CANopenDevice)'. The main window shows the 'CANopenDevice\_1' diagnostic log. The log header indicates 2 warnings, 0 errors, 0 exceptions, 13 informations, and 0 debug messages. The log table is as follows:

Severity	Time Stamp	Description
Warning	15.07.2019 10:50:37.516	NetID 0, NodeID 2: SDO Read Error for object 16#1000sub00
Information	15.07.2019 10:50:36.485	NetID 0, NodeID 2: Reading Device Type (Object 16#1000)...
Information	15.07.2019 10:50:36.485	NetID 0, NodeID 2: Bootup Timeout
Information	15.07.2019 10:50:34.435	NetID 0, NodeID 2: Waiting for Bootup message...
Information	15.07.2019 10:50:34.410	NetID 0, NodeID 2: NMT RESET
Warning	15.07.2019 10:50:34.389	NetID 0, NodeID 2: Heartbeat Timeout
Information	15.07.2019 10:48:14.335	NetID 0, NodeID 2: Slave signals CANopen state: OPERATIONAL
Information	15.07.2019 10:48:14.315	NetID 0, NodeID 2: NMT START
Information	15.07.2019 10:48:14.295	NetID 0, NodeID 2: SDO configuration phase finished
Information	15.07.2019 10:48:13.955	NetID 0, NodeID 2: Begin SDO configuration phase...
Information	15.07.2019 10:48:13.935	NetID 0, NodeID 2: Reading Identity Object 16#1018...
Information	15.07.2019 10:48:13.895	NetID 0, NodeID 2: Reading Device Type (Object 16#1000)...
Information	15.07.2019 10:48:13.895	NetID 0, NodeID 2: Slave signals CANopen state: BOOTUP
Information	15.07.2019 10:48:13.879	NetID 0, NodeID 2: Waiting for Bootup message...
Information	15.07.2019 10:48:13.877	NetID 0, NodeID 2: NMT RESET

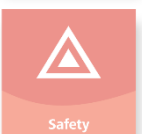
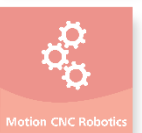
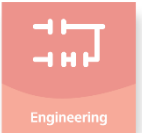

## Extensive improvements of diagnostic capabilities

- **Device tree: Errors visible even at collapsed device tree**

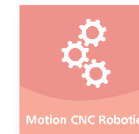
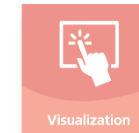
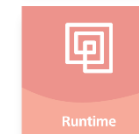
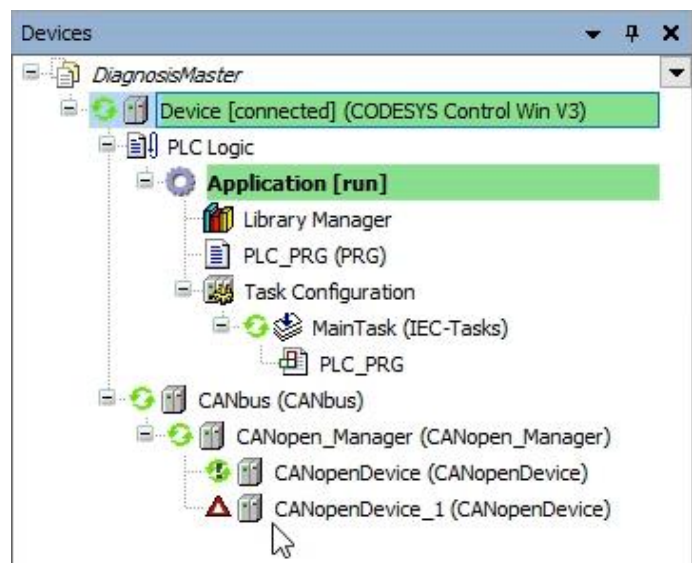
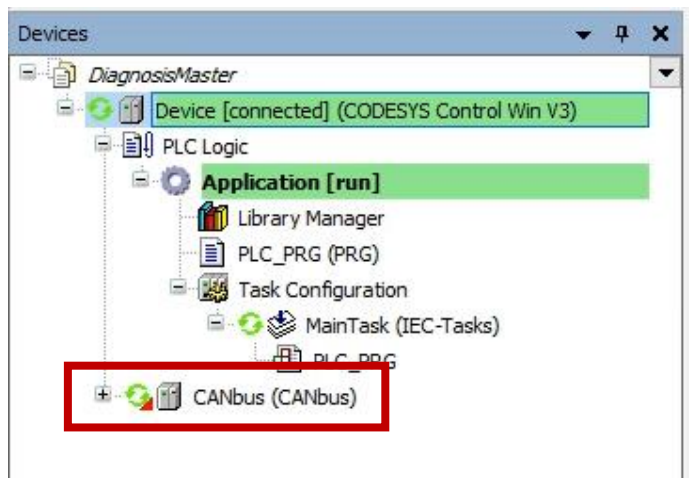

## Extensive improvements of diagnostic capabilities

- Notification about sporadic and self-healing cleared errors

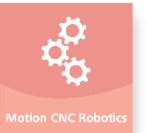
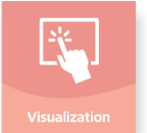
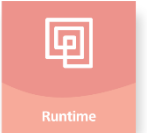
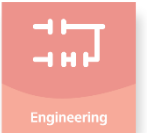
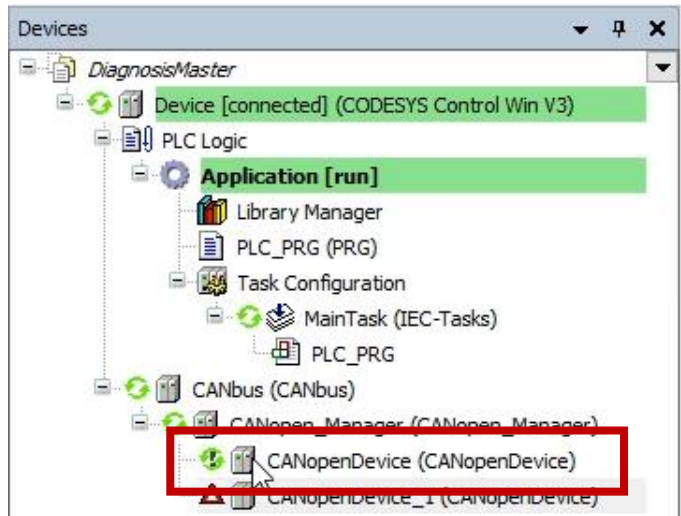

## Extensive improvements of diagnostic capabilities

- Acknowledgement of errors via context menu, even including subtree elements

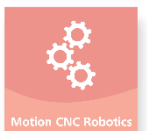
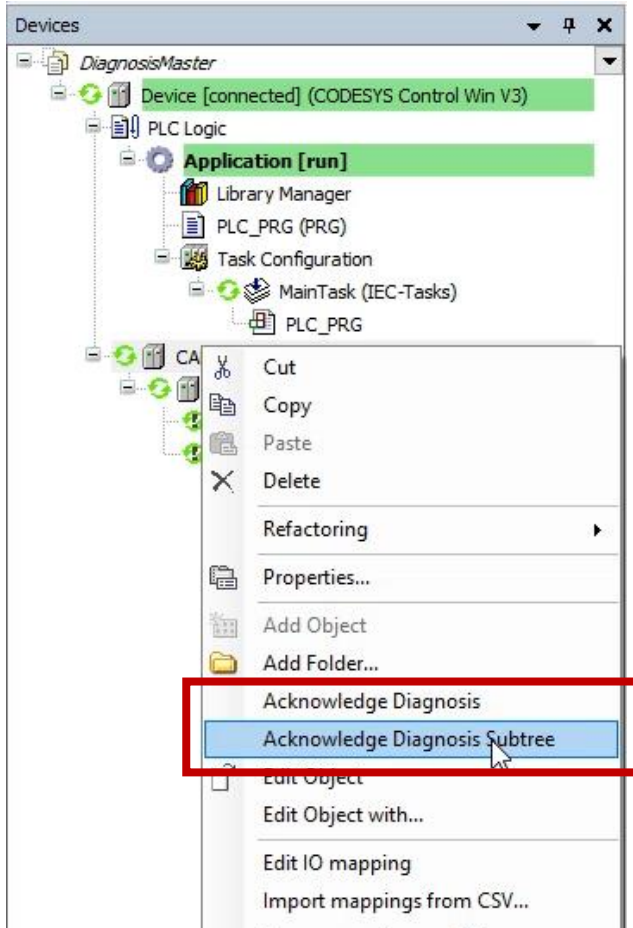

## Extensive improvements of diagnostic capabilities

- **CAA device diagnosis activated by default**  
*(for runtime systems with sufficient memory)*

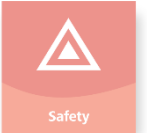
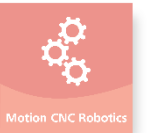
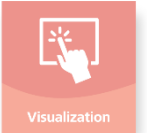
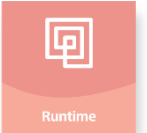
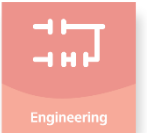
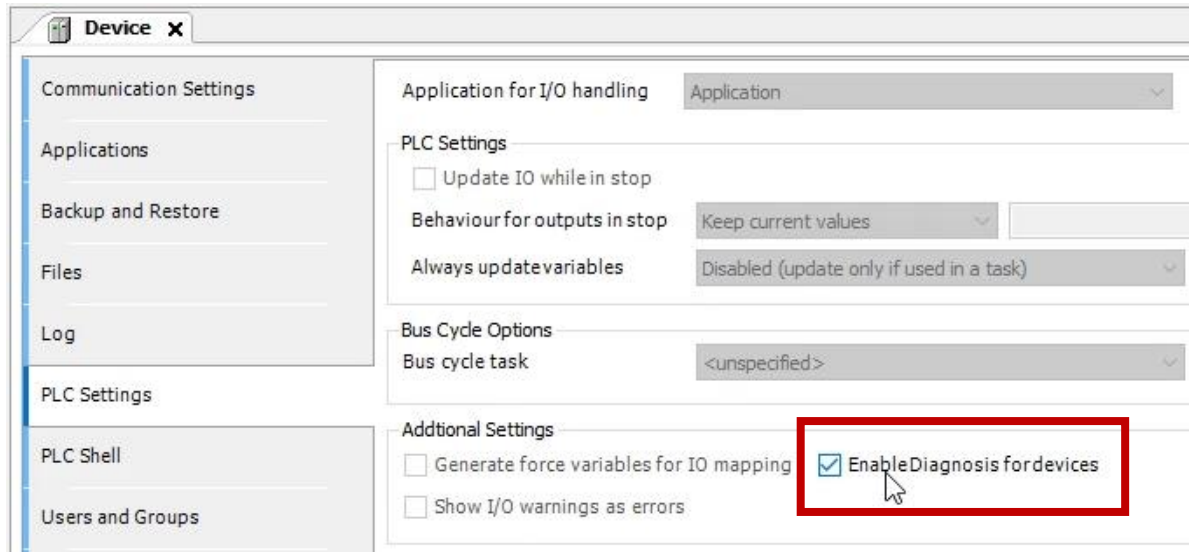



## Extensive improvements of diagnostic capabilities

- Implementation status of CODESYS 3.5 SP15

Fieldbus	Logger Page	Diagnostic Cleared
EtherCAT	✓ (Master) (Slave scheduled for SP16)	✓
ProfiNet Controller (IEC)	✓	✓
ProfiNet Controller (NetX)	✓	✓
ProfiNet Device (IEC)	✓	(Scheduled for SP16)
ProfiNet Device (NetX)	✓	(Scheduled for SP16)
Profibus	-	(Scheduled for SP16)
Ethernet/IP Scanner (IEC)	✓	✓
Ethernet/IP Scanner (NetX)	(Scheduled for SP16)	(Scheduled for SP16)
Ethernet/IP Adapter	✓	✓
CANopen Master	✓	✓
CANopen Slave	(Scheduled for SP16)	✓
J1939	(Scheduled for SP16)	(Scheduled for SP16)
Sercos	-	-
Modbus TCP/Serial	(Scheduled for SP16)	(Scheduled for SP16)

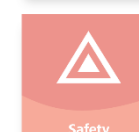
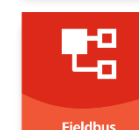
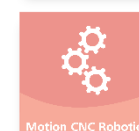
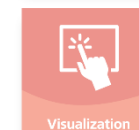
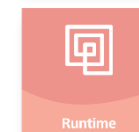
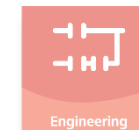

## CODESYS EtherCAT

- **Specific fieldbus diagnosis**
  - Diagnosis page for safety modules (FSOE diagnosis data)
  - Display of differences between configured devices and scan result after device scan
- **ESI file import**
  - Support of ESI file icons, e.g. for display in device tree and device repository
  - Significant performance improvement when importing large ESI files

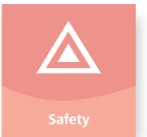
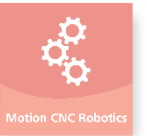
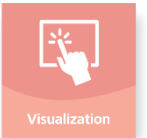
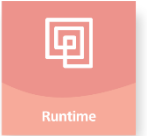
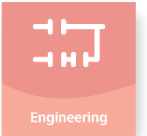

## CODESYS PROFINET

- **Specific fieldbus diagnosis**
  - PROFINET Controller
    - Detection of problems caused by firewalls
    - Implementation of diagnosis shadowing (for IEC and NetX stack)
  - PROFINET Device
    - Display of diagnostic data and submodule status on status page
- **IEC Controller and Device are PROFINET conformance test ready**
- **Reconfigure also possible on slave side**

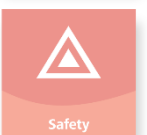
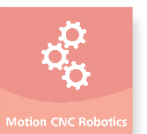
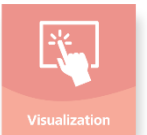
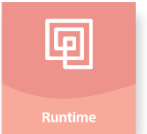
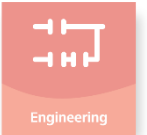

## CODESYS ETHERNET/IP Scanner/Adapter

- **Usability improvements**
  - Scanner configurator
    - Copy, cut and paste available in the assembly editor
    - Display of parameter groups shown in the configuration data view
    - In the I/O mapping I/O channels are grouped as folders by I/O connections
    - Display of EDS enumeration strings at connection configuration
  - Adapter configurator
    - Improved workflow at EDS export (import / export EDS button, analog to CANopen Slave)
- **Ethernet/IP Scanner (CIFX) with 64-bit support**

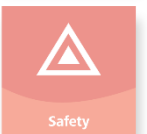
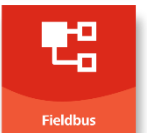
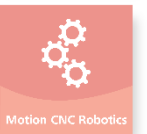
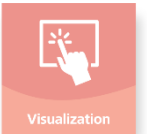
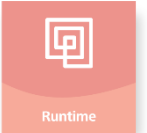
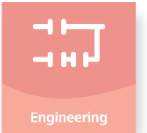

## CODESYS CAN

- **Specific fieldbus diagnosis**
  - Display of diagnostic data on status page for CANbus
- **CANopen redundancy for CANopen Master stack (in combination with CODESYS Redundancy Toolkit)**
- **No dynamic memory allocation for CAN LowLevel**
- **Support of newer firmware versions of Beckhoff EL6751**

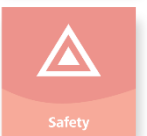
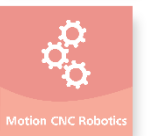
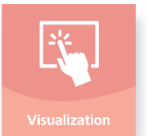
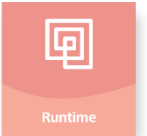
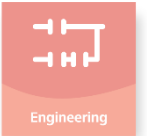

## CODESYS Modbus

- **Usability**
  - Move up / down buttons for channels
  - Channels can be renamed
- **Miscellaneous**
  - Holding register with bidirectional I/O channels for Modbus Slave, I/O channel can be written by stack and application

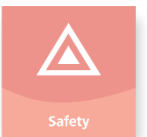
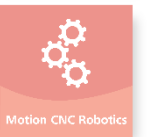
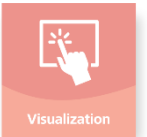
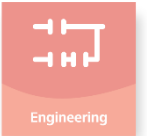

## Further improvements

- **Multiple selection for enabling / disabling devices**
- **Wago PFC100 / 200**
  - Support of 750-471
  - Hotplug support for modules

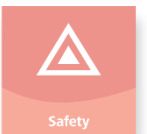
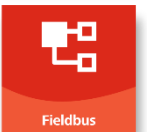
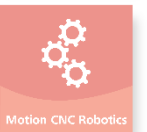
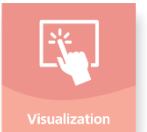
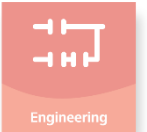

1

**Engineering**

2

**Runtime**

3

**Visualization**

4

**Motion CNC Robotics**

5

**Fieldbus**

6

**Safety**



## Overview

- **CODESYS F-Device**
- **CODESYS Qualification Kit for SIL3 Package**
- **CODESYS Safety for EtherCAT Safety Module (4.0.4)**

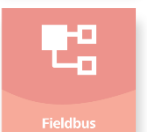
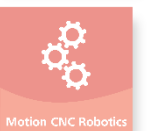
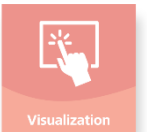
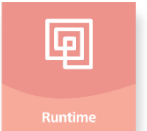
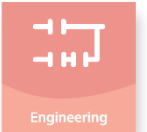

## CODESYS F-Device (CODESYS Safety 1.5)

- PROFINET Device (IEC) on CODESYS Control extendable to PROFIsafe Slave (“F-Device”)

Name	Vendor	Version	Description
Fieldbuses			
EtherNet/IP			
Modbus			
Profinet IO			
Profinet IO Device			
CODESYS Profinet Device	3S - Smart Software Solutions GmbH	3.5.15.0	CODESYS PLC running as Profinet Device.
CODESYS Profinet F-Device	3S - Smart Software Solutions GmbH	1.5.0.0	CODESYS PLC running as Profinet F-Device (derived from 3.5.13.0)
Profinet IO Master			

Name	Vendor	Version	Description
Fieldbuses			
Profinet IO			
Profinet IO Module			
Host-FInOut 2/2 PROFIdrive	3S - Smart Software Solutions GmbH	1.5.0.0	Exchanges 16 bit PROFIdrive status/control word with the F-Host
Host-FInOut 8/1	3S - Smart Software Solutions GmbH	1.5.0.0	Provides 2 x 32 bit PROFIsafe input to the F-Host and consumes 8 bit PROFIsafe output from the F-Host
Host-FInput 1	3S - Smart Software Solutions GmbH	1.5.0.0	Provides 8 bit PROFIsafe input to the F-Host
Host-FInput 123	3S - Smart Software Solutions GmbH	1.5.0.0	Provides 27 byte, 16 int, 16 dint PROFIsafe input to the F-Host (maximal PROFIsafe V2.6 size)
Host-FInput 13	3S - Smart Software Solutions GmbH	1.5.0.0	Provides 3 byte, 3 int, 1 dint PROFIsafe input to the F-Host
Host-FOutput 1	3S - Smart Software Solutions GmbH	1.5.0.0	Consumes 8 bit PROFIsafe output from the F-Host
Host-FOutput 123	3S - Smart Software Solutions GmbH	1.5.0.0	Consumes 27 byte, 16 int, 16 dint PROFIsafe output from the F-Host (maximal PROFIsafe V2.6 size)
Host-FOutput 13	3S - Smart Software Solutions GmbH	1.5.0.0	Consumes 3 byte, 3 int, 1 dint PROFIsafe output from the F-Host

- GSDML for including CODESYS controller as F-Device



Engineering



Runtime



Visualization



Motion CNC Robotics



Fieldbus



Safety

## CODESYS Qualification Kit for SIL3 Package

- Release scheduled for August 2019
- Allows for the qualification of an adapted version of the CODESYS Development System for the engineering of certified safety controllers / applications (according to ISO 13849 PL e or IEC 62061 / IEC61508 SIL 3)
- Target groups
  - Manufacturers or users of CODESYS compatible controllers with a CODESYS Development System adapted by means of plug-ins
  - Brand label customers of CODESYS safety controllers
  - Users of certified CODESYS safety controllers
  - Users of safety functions in an automation project

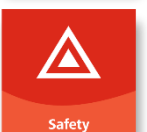
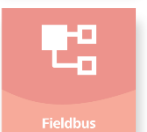
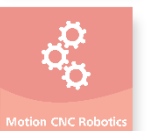
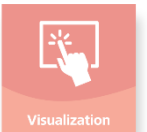
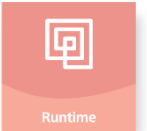
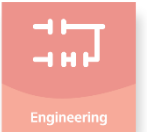

## CODESYS Qualification Kit for SIL3 Package

- **CODESYS Qualification Kit adds new functions to the CODESYS Development System:**
  - Installable with CODESYS Package Manager
  - Integrated editors for safety application with Safety FBD (using PLCopen safety function blocks SF\_EmergencyStop etc.) (\*)
  - Integrated configuration of safe field devices (FSoE and PROFIsafe) (\*)
  - Exchange of variables Safety PLC ↔ Standard PLC, Safety PLC 1 ↔ Safety PLC 2 (\*)
  - Online functions for Safety PLCs, e.g. administration, login, monitoring, debug mode, boot application
  - Check of the security application regarding coding rules, limited language set PLCopen basic / extended
  - Self-check of CODESYS installation and safety package
  - Safety user manual

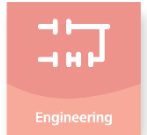

Engineering



Runtime



Visualization

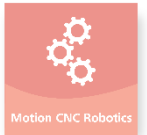

Motion CNC Robotics

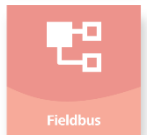

Fieldbus



Safety

(\*) Support depends on individual CODESYS Safety controller

## CODESYS Safety for EtherCAT Safety Module (4.0.4)

- **Second generation (EL6910, EK1960) allows to deactivate groups (POU + devices)**
- **Use case: if optional devices are not available and thus lead to errors**
- **Three functional elements**
  - Settings for deactivation in POU properties: Permanent, temporary, passivated
  - Specifiable replacement values for outputs if POU is deactivated
  - Online command: deactivation / activation status of groups

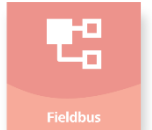
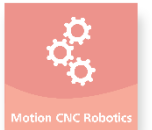
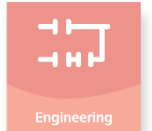
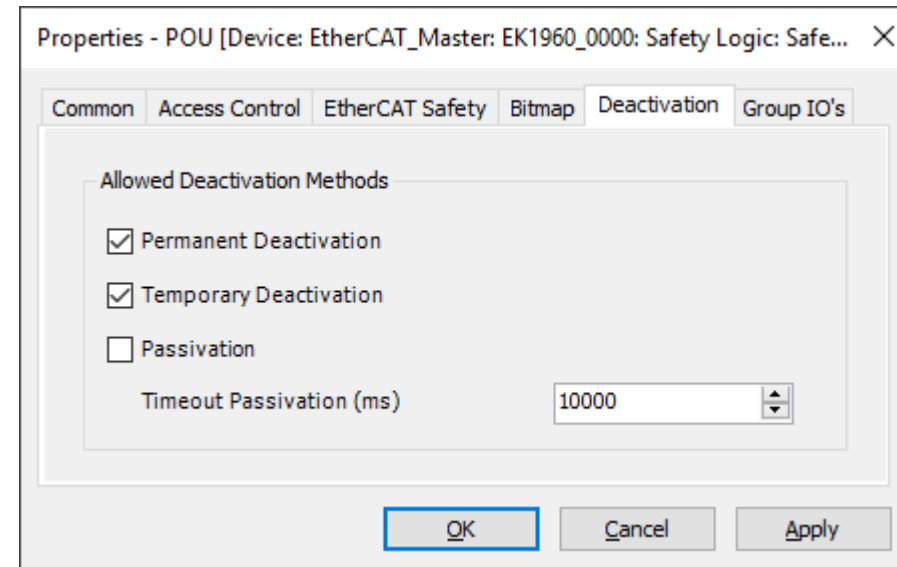
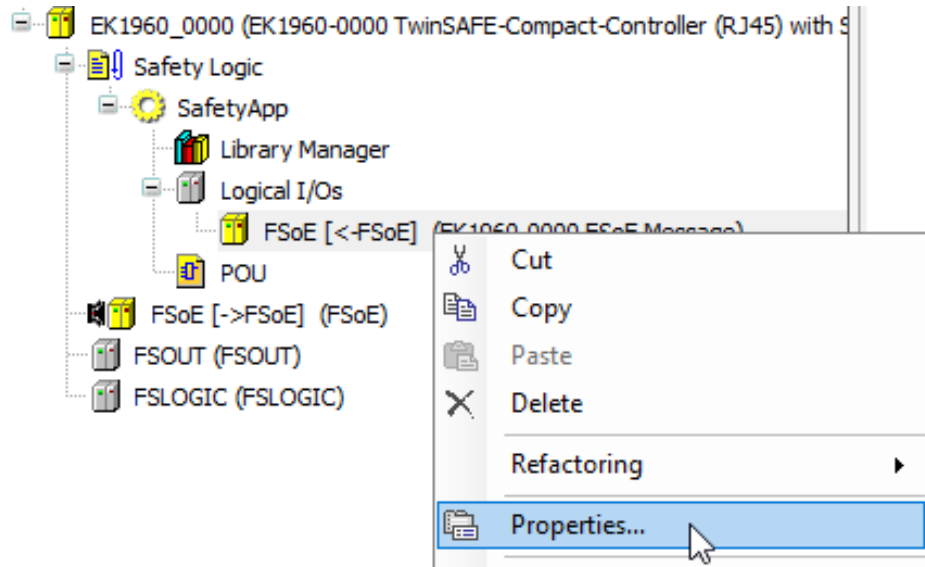

## CODESYS Safety for EtherCAT Safety Module (4.0.4)

- **Support of analog TwinSAFE Single Channel input modules by Beckhoff**
  - EL3124-0090 | 4-channel analog input terminal
  - EL3174-0090 | 4-channel analog input
  - EL3214-0090 | 4-channel input terminal PT100 (RTD) for 3-wire connection
  - EL3314-0090 | 4-channel thermocouple input terminal with open-circuit recognition
  - EL3356-0090 | Accurate 1-channel load cell analysis (resistor bridge)
  - EL5001-0090 | SSI encoder interfaces
  - EL5021-0090 | 1-channel SinCos encoder interface
  - EL5032-0090 | 2-channel EnDat 2.2 interface
  - EL5101-0090 | Incremental encoder interface (with differential inputs)
  - EL5151-0090 | 1-channel incremental encoder interface

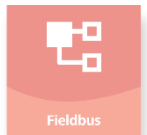
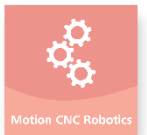
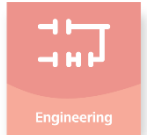



**Thank you for your attention.**

CODESYS® is a registered trademark. Technical specifications are subject to change.

Errors and omissions excepted. No reproduction or distribution, in whole or in part, without prior permission.

Note: Not all CODESYS features are available in all territories. For more information on geographic restrictions, please contact [sales@codesys.com](mailto:sales@codesys.com).